

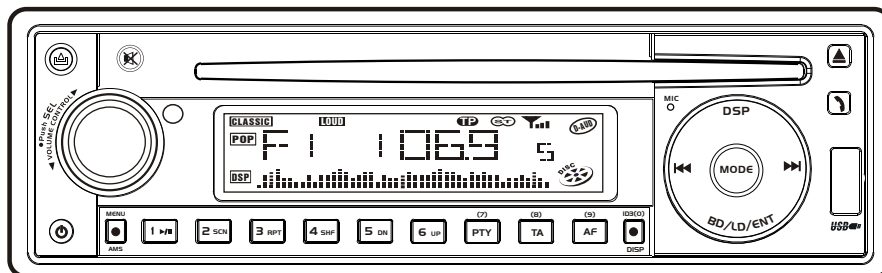

INSTRUCTION MANUAL

MODEL : A66HY

**CAR CD / MP3 PLAYER / RDS RECEIVER
WITH USB/SD/MMC INTERFACE
AND BUILT IN BLUETOOTH
HANDSFREE SYSTEM**



FUNCTIONS OF LOCATION

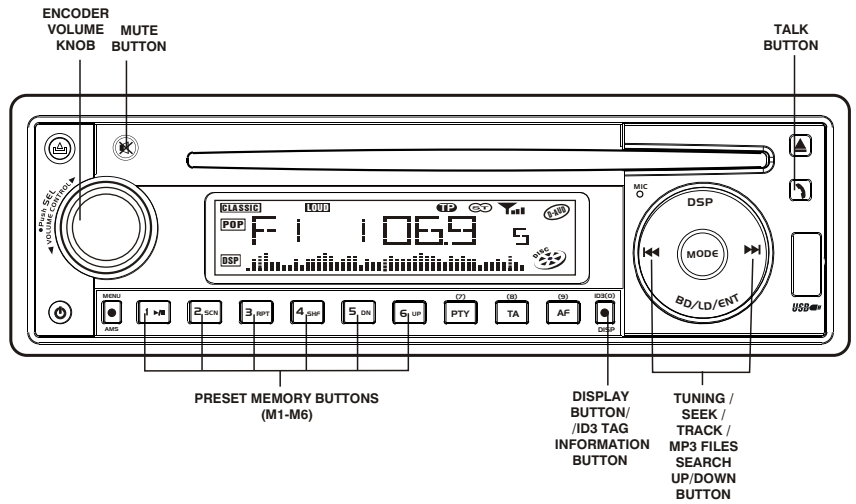
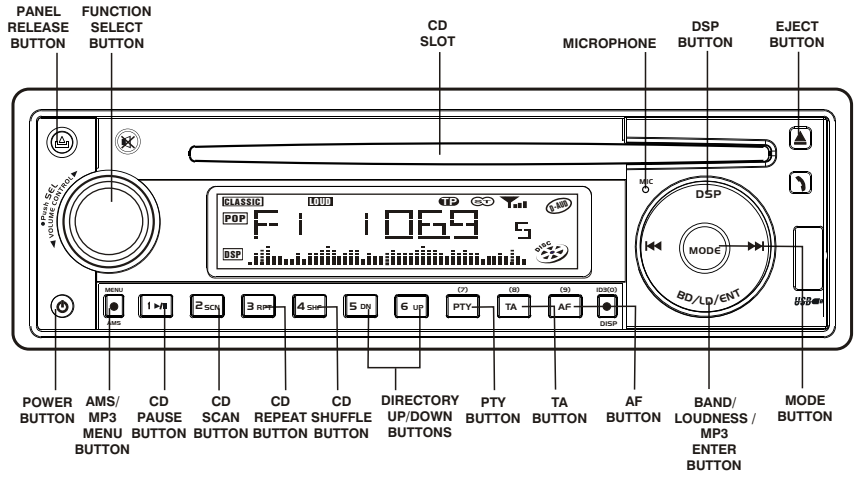

HANDLING COMPACT DISCS

MOISTURE CONDENSATION

On a rainy day or in a very damp area, moisture may condense on the lenses inside the unit. Should this occur, the unit will not operate properly. In such a case, remove the disc and wait for about an hour until the moisture has evaporated.

NOTES ON CDs

1. A dirty or defective disc may cause sound dropouts while playing. To enjoy optimum sound, handle the disc as follows.
Handle the disc by its edge. To keep the disc clean, do not touch the surface (P.1).



2. Do not stick paper or tape on the disc (P.2).

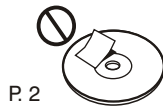

3. Do not expose the discs to direct sunlight or heat sources such as hot air-ducts, or leave them in a car parked in direct sunlight where there can be a considerable rise in temperature inside the car (P.3).



4. Before playing, clean the discs with an optional cleaning cloth. Wipe each disc from the centre out (P.4).

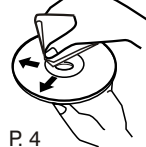

5. Do not use solvents such as benzine, thinner, commercially available cleaners, or antistatic spray intended for analog discs.

NOTES ON DISCS

If you use the discs explained below, the sticky residue can cause the CD to stop spinning and may cause malfunction or ruin your discs.

Do not use second-hand or rental CDs that have a sticky residue on the surface (for example, from peeled-off stickers or from ink, or glue leaking from under the stickers).

There are paste residue.
Ink is sticky (P.5).

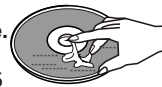

Do not use rental CDs with old labels that are beginning to peel off.

Stickers that are beginning to peel away, leaving a sticky residue (P.6).

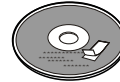

Do not use your CDs with labels or stickers attached.

Labels are attached (P.7).

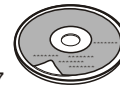

Do Not Use Special Shape CDs

Be sure to use round shape CDs only for this unit and do not use any special shape CDs. Use of special shape CDs may cause the unit to malfunction. (P.8).



Be sure to use CDs with disc mark



Only for this unit.

CD-Rs and CD-RWs which have not undergone finalization processing cannot be played. (For more information on finalization processing, refer to the manual for your CD-R/CD-RW writing software or CD-R/CD-RW recorder.) Additionally, depending on the recording status, it may prove impossible to play certain CDs record on CD-R or CD-RW.

INSTALLATION

- Before finally installing the unit, connect the wiring temporarily and make sure it is all connected up properly and the unit and system work properly.
- Use only the parts included with the unit to ensure proper installation. The use of unauthorized parts can cause malfunctions.
- Consult with your nearest dealer if installation requires the drilling of holes or other modifications of the vehicle.
- Install the unit where it does not get in the driver's way and cannot injure the passenger if there is a sudden stop, like an emergency stop.
- If installation angle exceeds 30° from horizontal, the unit might not give its optimum performance.

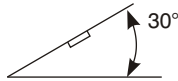

- Avoid installing the unit where it would be subject to high temperature, such as from direct sunlight, or from hot air, from heater, or where it would be subject to dust dirt or excessive vibration.
- Be sure to remove the front panel before installing the unit.

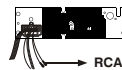

DIN FRONT/REAR-MOUNT

This unit can be properly installed either from "Front" (conventional DIN Front-mount) or "Rear" (DIN Rear-mount installation, utilizing threaded screw holes at the sides of the unit chassis). For details, refer to the following illustrated installation methods A and B.

DIN FRONT-MOUNT (Method A)

Installation the unit

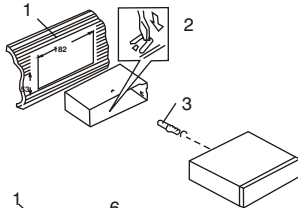

1. Dashboard
2. Holder
After inserting the half sleeve into the dashboard, select the appropriate tab according to the thickness of the dashboard material and bend them inwards to secure the holder in place.
3. Screw

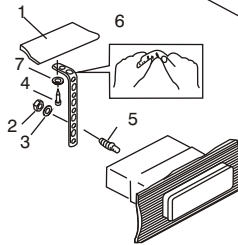

1. Dashboard
2. Nut (5mm)
3. Spring washer
4. Screw (5x15mm)
5. Screw
6. Support Strap
Be sure to use the support strap to secure the back of the unit in place. The strap can be bent by hand to the desired angle.
7. Plain washer

Removing the unit

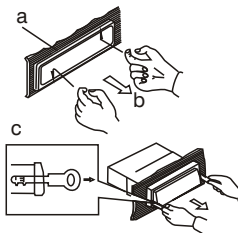

- a. Frame
- b. Insert fingers into the groove in the front of frame and pull out to remove the frame. (When re-attaching the frame, point the side with a groove down wards and attach it.)
- c. Insert the levers supplied with the unit into the grooves at both sides of the unit as shown in figure until they click. Pulling the levers makes it possible to remove the unit from the dashboard.

Trim Plate Installation:

Push the trim plate against the chassis until it is fitted.

You must do this before you install the front panel, otherwise it can't be attached.

DIN REAR-MOUNT (METHOD B)

Installation using the screw holes on the sides of the unit.
Fastening the unit to the factory radio mounting bracket.

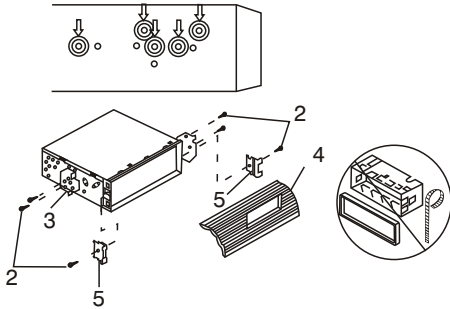

1. Select a position where the screw holes of the bracket and the screw holes of the main unit become aligned (are fitted) and tighten the screws at 2 places on each side.
2. Screw (must not use more than 6mm length)
3. Factory radio mounting bracket.
4. Dashboard or Console
5. Hook (Remove this part)

Note: the mounting box, outer trim ring, and half-sleeve are not used for method B installation.

DETACHABLE CONTROL PANEL (D.C.P.)

Removing The Detachable Control Panel (D.C.P.)



1. Turn the power off
2. Press the D.C.P. release button
3. Remove the D.C.P.

Attaching the DCP

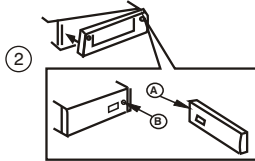

1. Attach the panel at the right side first, with point B on the main unit touching point A on the D.C.P. (As shown on the diagram).
2. Then press the left side of D.C.P. onto the main unit until a "click" sound is heard.

CAUTION

- DO NOT insert the D.C.P. from the left side. Doing so may damage it.
- The D.C.P. can easily be damaged by shocks. After removing it, place it in a protective case and be careful not to drop it or subject it to strong shocks.
- When the release button is pressed and the D.C.P. is unlocked, the car's vibrations may cause it to fall. To prevent damage to the D.C.P., always store it in a protective case after detaching it.
- The rear connector that connects the main unit and the D.C.P. is an extremely important part. Be careful not to damage it by pressing on it with fingernails, pens, screwdrivers, etc.

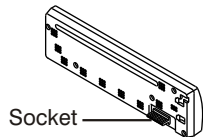

Note:

If the D.C.P. is dirty, wipe off the dirt with soft, dry cloth only. And use a cotton swab soaked in isopropyl alcohol to clean the socket on the back of the D.C.P.

IMPORTANT

These 2 screws are used to prevent damage to the CD mechanism during transportation. Please make sure to remove the 2 screws before installing the unit into the vehicle. DO NOT insert a CD into the unit before removing the 2 screws.

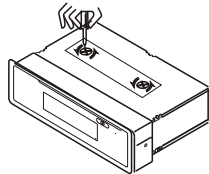

ELECTRICAL CONNECTION

- a. Make sure your car battery is a 12 volt (6 filler caps) negative ground system (if not, a converter will be necessary).
- b. Before starting wiring connections, disconnect the power supply by removing the fuse from the fuse box.
- c. Connect the power wire to one of the extra terminals of the fuse box.
- d. Connect the black ground wire to a metal part of the car. It is important to make good contact.
- e. Make other wiring connections as shown.
- f. If your car does not have ISO connector, you can procure it from any car accessory shop.

Notes: INCORRECT WIRING OR OPERATION WILL AVOID THE WARRANTY OF THIS UNIT

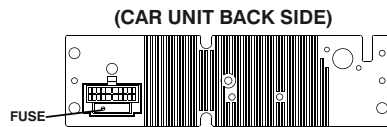

Fuse Replacement:

To replace the fuse, pull out the blown fuse from the socket. Insert a new one with same rating

BASIC OPERATIONS

PANEL RELEASE BUTTON

Press this button to remove the control panel.

POWER BUTTON

Press this button to turn on or off the power.

DISPLAY BUTTON

For RDS models:

Press this button to view other information such as clock , RDS information, band and frequency ...etc.

MODE BUTTON

Press this button to select different mode, sequence as follow:

MODE PRIORITY

- A) Tuner mode (Radio)
 - B) CDP/MP3 (only if a CD or MP3 disc is inserted)
 - C) USB (only if a USB drive is inserted)
 - D) SD/MMC (only if a SD or MMC card is inserted)
- Whenever a USB or SD/MMC is being inserted, unit will automatically switch to USB or SD/MMC mode, does not matter the unit is currently in what mode.
- When in USB or SD/MMC mode, if the USB or SD/MMC is being removed, unit will automatically switch to previous mode.

RESET BUTTON

The RESET button is located on the main unit (as shown on the diagram). To press it vertically with a ballpoint pen or metal object will activate it. The reset button is to be activated for the following reasons:

- Initial installation of the unit when all wiring is completed.
- All the function buttons do not operate.
- Error symbol on the display.

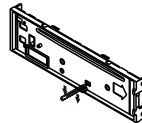

Note: If press RESET button, the unit still cannot function normally, please use a cotton swab soaked in isopropyl alcohol to clean the socket on the back of the control panel.

AUDIO OPERATIONS

ENCODER VOLUME KNOB

Turn this knob to adjust desired volume level.

FUNCTION SELECT BUTTON

Press this button to select desired audio function.

ORDER OF FUNCTION:

VOLUME(VOL) -> BASS(BAS) -> TREBLE(TRE) -> BALANCE(BAL) -> FADER(FAD)

While the selected function is displayed, turn Volume Knob to adjust the level within 5 seconds, otherwise the unit will return to volume adjustment mode.

MUTE BUTTON

Press this button to mute the sound. Press it again to resume listening.

DSP BUTTON (DIGITAL SOUND PROCESSOR)

Press this button to toggle the following EQ setting:

▢ FLAT->CLASSICS->POP M->ROCK M->DSP OFF ▢

At DSP OFF mode, EQ will be controlled by Bass/Treble setting.

BAND/LOUDNESS BUTTON

Press the Band/Loudness Button long to switch the loudness on or off. When Loudness is on, display will show 'Loud On' for a few seconds.

RADIO OPERATIONS

BAND/LOUDNESS BUTTON

This a dual function button. Press this button short to change between BAND FM1, FM2, FM3 & AM bands. Press it long to turn on or off Loudness function.

TUNING / SEEK UP AND TUNING / SEEK DOWN BUTTONS

1. Press these buttons briefly will operate AUTO SEARCH tuning mode, the radio will tune up or down to the next station and remain on the frequency.
2. Press these buttons more than 2 seconds, operate as MANUAL SEARCH buttons, under this mode the tuning frequency will advance up or down rapidly when the button is pressed. If the buttons are not pressed within 3 seconds, they will return to auto search mode.

RADIO SIGNAL STRENGTH METER

This is use to indicate the signal strength of current radio station broadcast. When you choose RADIO mode, it will show on the display.



AUTO MEMORY STORE/PRESET SCAN BUTTON (AMS)

- 1.PRESET SCAN: Press AMS button briefly enter Preset Scan mode, it will scan all the preset stations in the memories, you can hear that will stay on each station for about 5 seconds.
- 2.AUTO MEMORY STORE: Press AMS button long to enter Auto Store mode, this feature will automatically scan the current band and enter up to 6 strongest stations into the 6 preset memories. To stop Auto Store & Scan, press the AMS button again.

STATION PRESET BUTTONS (M1-M6)

- 1.Press these buttons briefly to recall the stored stations in the selected band.
- 2.Presetting stations manually, Press the BAND button to select the band for the station to be preset. Use Tuning Up/Down to tune in the stations to be preset. Press the Preset button at which you want to store the station for at least 2 second. The preset number will appear on the display accompanied by a beep, this indicate that the station has been stored into memory.

CD OPERATIONS

CD SLOT

Insert the disc into CD slot. The CD will begin to play.

CD PAUSE BUTTON

Press this button to pause CD play, press again to release pause.

CD SCAN BUTTON

Press this button, the first 10 seconds of each track will be played sequentially until this button is pressed again, then normal play will resume at the current track.

CD REPEAT BUTTON

Press this button, the current track will be played repeatedly until this button is pressed again.

CD SHUFFLE BUTTON

Press this button to play all tracks on CD in random. Press again to deactivate it.

EJECT BUTTON

Press this button to eject the CD from the unit. The receiver will switches to radio mode automatically.

TRACK UP AND TRACK DOWN BUTTON

Press the Track Up Button to skip to the next track or previous track. Press the Track Down button during play will return to the beginning of the current track, press it one more time to skip to previous skip. Press and hold Track Up/Down Button to fast forward or fast reverse. CD player starts when you release the button.

RDS OPERATIONS

OVERVIEW OF THE RDS FUNCTION

Radio Data System (RDS) is a broadcasting service that allows FM stations to send additional digital information along with the regular radio program signal. Your car stereo offers you a variety of services. Here are just a few:

- **PI (Program identification)**

It is a code that identified RDS stations; it is unique for each station.

- **PS (PROGRAM Service Name)**

The name of current station, it is shown on the display.

- **AF (Alternative Frequencies List)**

The list(s) of Alternative Frequencies give information on the various transmitters broadcasting the same program in the same or adjacent reception area. If the main frequency should get worse, the radio will tune automatically to the strongest Alternative frequency.

- **TP (Traffic Program)**

If the tuned program carries Traffic Announcement, the TP indicator will turn on.

- **TA (Traffic Announcement)**

When an actual traffic bulletin is on air, the TA indicator will also turn on.

- **PTY (Program Type Codes)**

This code is used to designate the current program material being broadcast. With this feature, you can search the programs that match the selected program type, which is chosen from a specific list of types.

- **CT (Clock Time)**

This function permits to update the clock of the receiver the nation from which the station is broadcasting (from PI). It could happen that on the display will be shown the wrong hour; this happens because in Italy the Clock Time function is not working yet.

Notes

- Depending on the country or region, not all of the RDS functions are available in Italy.
- RDS may not work properly if the signal strength is weak or if the station you are tuned to is not transmitting RDS data.

PROGRAMMABLE OPTIONALS

To use this function keep press long **SEL** Button for few seconds, each time you press this button the mode will move and the functions will shown on the display, turn the **encoder volume knob up/ down** to set the desires functions ,the function states as following:

- **TA SEEK, TA ALARM**

To determine what action will the radio take if the newly tuned station does not receive TP information for 5 seconds.

TA SEEK

The radio retunes to a different station which contains TP information.

TA ALARM

The radio does not retune but beeps will come out.

- **PI SOUND, PI MUTE**

When the vehicle is crossing the area where two stations with same AF but different PI code can be received at the same time, the receiver will become unstable, under this situation two modes can be selected.

PI SOUND

The different PI sounds will be heard.

PI MUTE

Under the same situation, the radio will be muted.

- **RETUNE L, RETUNE S**

To determine the initial time of automatic TA Search or PI Search.

RETUNE L 90 seconds

RETUNE S 30 seconds

- **MASK PI, MASK ALL**

"PI" is referred to "Different PI with same AF".

During AF search, PI stations and non-RDS stations with strong signal will be masked, in the latter case, the non-RDS stations may cause interference, resulting the real AF to be masked due to the misjudgment of the radio under interference.

There are two options to handle this situation.

MASK PI to mask only the AF with different PI.

MASK ALL mask both PI and strong signal non-RDS stations.

- **BEEPS 2ND, BEEP ALL, BEEP OFF**

To determine how the beep sound is generated when the keys are pressed.

BEEP 2ND Beeps only when the second function of the dual function button is selected (long press).

BEEP ALL Beeps when any buttons is pressed.

BEEP OFF To disable the beep option.

RDS OPERATIONS

AF BUTTON

Press this button briefly to switch on or off the AF follow mode, the state of the AF follow mode will be indicated on the LCD by the "AF" icon:

Icon Off : AF follow mode off

Icon On : AF follow mode on and RDS reception OK

Icon Flashing : AF follow mode selected, but no RDS data received

When AF follow mode is on, the radio will from time to time measure the signal strength of the alternative frequencies that come with the RDS data. When an alternative is found stronger than the current frequency in several measurements, the radio will switch over to that

When this button is pressed for more than 2 seconds, the unit enters Regional mode and the Regional mode status will be displayed on the LCD as "REG ON" and "REG OFF" for a few seconds.

Some broadcasting stations may change their program from normal broadcasting to regional broadcasting for a certain period. When regional mode is off, the region identification in the PI code is ignored, the radio may switch to a local variant of the current program. When region mode

Note: When AF switch is on, at this moment use Tuning Up/Down to search station will only stop at station which has RDS broadcasting.

TA BUTTON

Press this button briefly to turn on or off the TA mode.

A traffic stations will transmit traffic announcement together with the normal broadcasting periodically, when TA mode is on and traffic announcement is being broadcasted, the radio will temporary switch to the reception of traffic announcement even the unit is under tape or CD mode or even the unit is muted.

The status of TA is indicated by two indicators on the LCD, "TA" and "TP", When TA is turned on, the TA indicator will light up, if the current station carries Traffic Announcement, the TP indicator will turn on.

Note: When TA switch is on, at this moment use Tuning Up/Down to search station will only stop at station which has TA broadcasting.

PTY BUTTON

Each time when this button is pressed, the PTY mode will toggle in the following order:

PTY Music Group->PTY Speech Group->PTY off

The current PTY code is displayed on the LCD, use the 6 preset buttons to select the other PTY code, the distribution of program type are as follow :

Button Number	Music Group	Speech Group
1	POP, ROCK	NEWS, AFFAIRS, INFO
2	EASY, LIGHT	SPORT, EDUCATE,
3	CLASSICS,	CULTURE, SCIENCE,
4	JAZZ, COUNTRY	WEATHER, FINANCE,
5	NATION, OLDIES	SOCIAL, RELIGION, PHONE IN
6	FOLK	TRAVEL, LEISURE, DOCUMENT

When PTY code is selected, the radio will search the band for the station that matches the PTY code.

MMC/SD CARD & USB DEVICE OPERATIONS

START THE USB DEVICE MODE

1. The USB socket is accessible as indicated in picture 1.(P.1)
2. Plug in the USB drive / device completely as indicated in picture 2(P.2) and display will show "USB PLAY" to indicate that the USB drive / device is being plugged in correctly & the download has begun.
3. Does not matter the unit is in what mode (TUNER, CDC, CD, SD/MMC, etc), once a USB drive / device is being plugged into the unit, unit will automatically switch to USB mode.
4. All the USB files playback function is same as normal CD or MP3 disc playback.

Warning: Excessive weight or size USB drive/device may cause permanent & serious damage to the unit and may cause access to the buttons on the front panel impossible. User must use an extension cable (provide by USB device manufacturer) to connect with USB socket to prevent any damage cause.

TO STOP USB PLAYBACK

1. The USB drive / device is unplugged, the unit automatically switch to radio mode. Or user can use mode button to switch to other mode.
2. User can use the mode button to choose USB mode (only if USB drive / device is inserted in the unit) or any other modes, when they are in any mode.

USB SPECIFICATION

- * SUPPORT MAX 1G USB FLASH MEMORY
- * SUPPORT MAX 255 SONGS
- * USB 1.1 DEVICE SUPPORT
- * USB 2.0 DEVICE SUPPORT
(TRANSFER SPEED SAME AS VER 1.1)
- * FILE MANAGER: FAT12/FAT16/FAT32
- * CURRENT SUPPLY: MAX 500mA

CAUTION

1. Always unplugged the USB gently from the unit, excessive force used will cause permanent & serious damage to the unit & the USB drive / device.

COMPATIBILITY

Due to the fast changing technology world, this unit may or may not be compatible to all the USB drive / device available with all the future technology, especially those USB drive / device which require to install a driver. Always choose a compatible USB drive / device which is compatible with this unit.

NOTE:

This unit is not compatible with portable Hard-Disc.

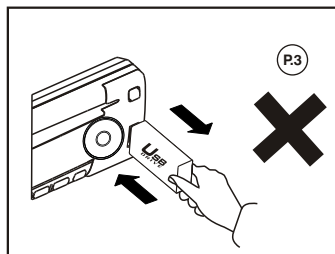
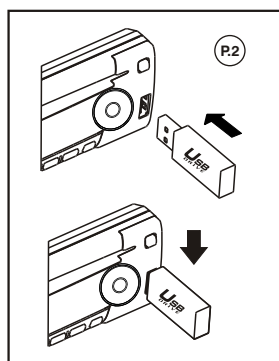
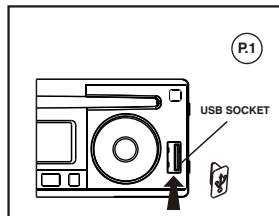

START THE SD/MMC MODE

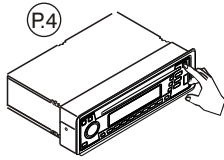

1. Press panel release button to release the front panel.(P.4)
2. The SD/MMC card slot is located on top of the front panel as indicated in (P5).
3. Insert the SD/MMC card into the card slot in the correct direction until a "CLICK" sound is heard.
4. Close the front panel.
5. The display will show "SD PLAY" to indicate that the SD or MMC card is correctly inserted. Once the SD or MMC card is inserted, the MP3 file will automatically loaded & playback will also start.
6. Does not matter the unit is in what mode (Tuner, CDC, CD, USB, etc), once a SD or MMC card is being inserted in the unit, unit will automatically switch to SD / MMC mode.
7. All the SD / MMC files playback function is same as normal CD or MP3 disc playback.

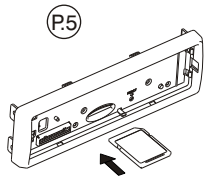

TO STOP SD/MMC CARD PLAYBACK

1. Push on the end of the SD or MMC card to eject the sd or MMC card. Once the SD or MMC card is taken out, the unit will automatically switch to previous mode.
2. User can use the mode button to choose SD / MMC mode (only if SD or MMC is inserted in the unit) or any other modes, when they are in any mode.

SD/MMC SPECIFICATION

- * SUPPORT MAX 1G SD/MMC CARD
- * SUPPORT MAX 255 SONGS

CAUTION

2. Please make sure to insert the SD or MMC card in the correct direction / orientation as indicated in picture 6(P6). Wrong insert will cause permanent & serious damage to the unit & the SD or MMC card.

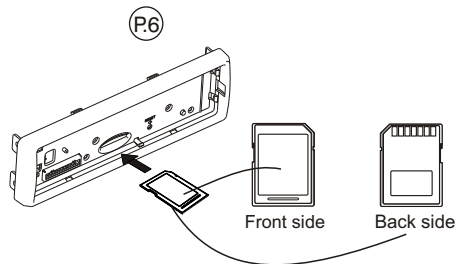

MP3 OPERATIONS

Notes :

- An MP3 directory is shown in this manual as "Directory", and an MP3 file is shown as "Track".
- Maximum length of file name : 28 characters.
- Maximum length of directory : 16 characters.
- Maximum number of tracks per disc : 254.
- Maximum number of directories per disc : 128.
- Sampling Frequencies support : 32KHz, 44 KHz, 48KHz.
- Bit Rates support : 64 - 320KHz including VBR.
- Supports Multi-Session recording.
- Supports CD, CDR and CDRW. (Playback of MP3, CD-R and CD-RW may depend on recording conditions)
- Disc written by Packet Write (UDF) is not supported.
- Supports Max 255 songs for MP3 Disc, USB device or SD/MMC Card.

LOADING CD

Insert the CD as usual, if it is an MP3 CD, the display will show "MP3 T01" then the message "READING" will appear, when disc scanning completed, the first track on the first directory will play.

NAVIGATING THROUGH DIRECTORIES AND TRACKS

There are four ways to select your favorite track/directory

(1) By track Number

A) Under MP3 play mode, press MP3 Menu button once, the display shows "MP3 T*", enter the desired track number directly, then press MP3 Enter button to confirm. The distribution of the number are listed as follow:

Number	1	2	3	4	5	6	7	8	9	0
Button	M1	M2	M3	M4	M5	M6	MODE	TUN DN	TUN UP	DISP

B) Turn the Encoder Volume knob to skip the current track.

(2) By directory or Track Name

Under MP3 Play Mode, press MP3 Menu button twice, the display shows " * ", enter the name directly, Press Mp3 Enter button to confirm. The distribution of alphabetical characters are listed as follow :

Button	M1	M2	M3	M4	M5	M6	MODE	TUN DN	TUN UP	DISP	SEL	VOL UP/DN
Character	A,B,C	D,E,F	G,H,I	J,K,L	M,N,O	P,Q,R	S,T,U	V,W,X	Y,Z, Space	_,-,+	Move Cursor	Next/Previous Character

If partial directory/Track name is entered, then all directory/Track with matched characters are displayed, Turn the Encoder Volume knob to go through the list, press MP3 Enter button to confirm.

If directory name is selected, the display will show " \\", under this condition, Turn the Encoder Volume knob to select the tracks under the directory, press MP3 Enter button to confirm.

(3) To select directory first

Under MP3 play mode, press MP3 Menu Button three times, Then the first directory name is shown.

Turn the Encoder Volume knob to navigate through the directory list, press MP3 Enter button to select the desired directory. The display will show " \\". Turn the Encoder Volume knob to select the tracks under the selected directory, press MP3 enter button to confirm when desired track is found.

(4) Navigating through Directory directly

Press Directory Up(M6) or Directory Down buttons(M5) to skip the current Directory forward or backward by one position.

In a multi-level directories disc, the movement will take place at the current level until the last directory is reached.

The next directory down operation will move the position down by one level.

ID3 TAG

Press DISPLAY button repeatedly to Display ID3 TAG information.

If the MP3 file is available with ID3 TAG, pressing the display button repeatedly will show information in the following sequence:

SONG TITLE > ARTIST> ALBUM TITLE

If any of the ID3-TAG information is not available, pressing the DISPLAY button repeatedly will show information in the following sequence:

UNKNOWN SONGNAME> UNKNOWN ARTIST> NO ALBUM TITLE

If the MP3 file is without ID3 TAG, pressing the DISPLAY button, & "NO ID3 TAG" will be displayed.

The file name & track number of the MP3 file will scroll repeatedly through the display during the playing of the MP3 file.

INSTRUCTION FOR HANDFREE FUNCTION

SET UP

- a. Press panel release button to release the front panel.
- b. The PAIR button is located on bottom right of the front panel as indicated.
- c. Press PAIR Button about 4 seconds, the LED indicator twinkle rapidly, and it enters into Pairing Mode (Headset or handsfree profile or both).
- d. Turn the phone to Bluetooth Menu, then scan Bluetooth set named CAR_AUDIO_HF and enter the connecting password (0000) to connect Bluetooth set after successful scan.
- e. Close the front panel.
- f. Single click TALK button, the phone will display symbol(</>), the phone can be used as normal.
- g. To check the connecting status, from TALK button or release front panel again can find the Pairing LED indicator Flashes once every 4 seconds.

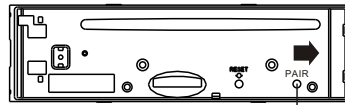

PAIR BUTTON

OPERATION

- Call Accept: Single click TALK button at in call time, means accept the incoming call.
- Call Reject: Click TALK button about 1.5 seconds at in call time, means reject answer the call.
- Call Disconnect: Single click TALK button when communication or dialing an outgoing call, means hang up.
- Call Waiting (Depend on provider feature): Double click TALK button at communicating time, enter into call waiting, double click it again, enter into communication mode.
- Call Transfer (Private mode): Click TALK button about 1.5 seconds at communicating time, transfer the call to phone, click talk button once again, transfer the call to Bluetooth.
- Last Number Redial: Double click TALK button when not in call, dial the last out-call number on the phone automatically.
- Auto Answer (Depend on mobile phone feature): Pls refer to your own mobile phone manual for handsfree auto answer setting.
- Volume Adjust: User can use the volume up/down to adjust the volume level.

BLUETOOTH NOTICE

In Bluetooth headset and handsfree profile, if the mobile phone have been restart or back to the receiving area of the Bluetooth again, it need press the TALK button to connect the Bluetooth set and the phone for normal use otherwise audio transfer will not be back from mobile Phone to Head unit.

Before you start to use our Bluetooth HEAD UNIT, please pairing with your mobile phone completely. Please refer to the section of **Set Up**. To ensure the best reception for Pairing & Re-connection, please make sure the Phone Battery is fully charged when making the Pairing or Re-connection.

- The Bluetooth symbol (...) and the connected symbol (< / >) on the mobile phone will be different from one to another. Please refer to the corresponding specification.
- The TALK Button LED turns on when an audio connection exists (e.g. talking) or when it is ringing.
- When the main unit turns on, if there is a call incoming, it will auto switch to talk state.
- When you hang up the phone, the main unit will revert to previous state (radio, CD or other mode).
- When the main unit turns off (with ACC ON), if there is a call incoming, the main unit will auto turn on and enter into talk mode. When hang up the phone, the main unit will turn off automatically.
- Some brand of Mobile Phone like Sony Ericsson may have "Power Saving Mode" selection when Blue Tooth mode is switched on. **PLEASE DO NOT** Switches ON "Power saving Mode" when operating with this Head Unit. As some abnormal communication behavior will happen occasionally if Power Saving Mode is switched on.
- To ensure the best conversation quality / performance, please always keep talking within 1 meter of the Head Unit.
- Some Mobile Phones can support "IN BAND RING TONE", such as Motorola, Nokia. In such case, the Incoming Ringing Tone will be same as the original Ring-tone of the Mobile Phone.
- But some Mobile Phones like Sony Ericsson do not support this feature. The Ring-tone will be using the standard Ring-tone of the Head unit.
- Using voice dialing, please make sure the phone and the 'head unit within 3 meters of each other. Also please make sure your mobile phone support voice dialing function. And please consult with your mobile phone supplier if you want to know the operation further about voice dialing.
- If user want to Dis-connect the Head unit with the Mobile Phone, please click talk button once or switch "OFF" Blue Tooth connectivity on the Mobile Phone.

Specifications for Blue tooth

BLUE TOOTH

Power Consumption	200mA Max.
Output Power	0 dBm (Class II)
Frequency Band	2.4GHz ~ 2.4835GHz ISM Band
Range	3 meters (free space)
Standard	Bluetooth 1.2 specification
Ericsson	R520m, T39
Motorola	E398, V501, V600, V3, E1000, E680i
Nokia	8910, 6310i, 6600, N-gage, 6260, 6230i, 6680, 3230, 7610
Panasonic	X70
Sony Ericsson	T68i, Z600, T610, T630, P800, P900, P910i, K700i, K750i, W800i
Samsung	D608
Siemens	S55, S65

- Specifications and the compatibility phone list subject to change without notice.

Remark:

Our Bluetooth Handsfree System adapts to the Bluetooth spec V1.0 and higher. It is compatible with profiles such as Handsfree profile and Head Set profile. However the functionality may be limited due to some phones dedicated interfacing specifications, even with phones of which the actual Bluetooth specifications and used profiles apply to our Bluetooth Handsfree System specifications.

Please check the compatibility list or try it out in practice your phone at the local dealer in case it is not mentioned in the list.

Note:

Compatibility and connectivity with all Bluetooth mobile phones is not guaranteed.

Warning:

Many jurisdictions have laws regarding the use of a phone in a vehicle environment. Obey all local laws. Always keep your hands free to operate the vehicle while driving. Your first consideration while driving should be road safety.

SPECIFICATIONS

CD PLAYER

System	Compact disc audio system
Usable disc	Compact disc, CD-R, CD-RW (AUDIO/MP3 format)
Sampling frequency	44.1KHz
No of quantization bits	1bit
Frequency	5-20,000Hz
Number of channels	2 stereo
S/N Ration	70dB

RADIO SECTION

FM

Frequency Range	87.5 - 108 MHz
Intermediate Frequency	10.7 MHz
Usable Sensitivity	Better than 15dB at S/N 30 dB
Stereo Separation	25 dB at 1KHz
S/N Ratio	50 dB

AM (MW)

Frequency Range	522 - 1620 KHz
Intermediate Frequency	450KHz
Usable Sensitivity	Better than 45dB
S/N Ratio	40 dB

GENERAL

Power Supply	DC 11 -14V
Polarity	Negative Ground
Speaker impedance	4 ohms
Power Output	40W x 4

REMARK :

Specifications subject to change without notice.

TROUBLE SHOOTING

Before going through the check list, check wiring connection. If any of the problems persist after check list has been made, consult your nearest service dealer.

Symptom	Cause	Solution
No power	The car ignition is not on.	If the power supply is properly connected to the car accessory terminal, switch the ignition key to "ACC"
	The fuse is blown.	Replace the fuse.
Disc cannot be loaded or ejected	Presence of CD disc inside the player.	Remove the disc in the player, then put a new one.
	Inserting the disc in reverse direction.	Insert the compact disc with the label facing upward.
	Compact disc is extremely dirty or defective disc.	Clean the disc or try to play a new one.
	Temperature inside the car is too high.	Cool off or until the ambient temperature returns to normal.
	Condensation.	Leave the player to off for an hour or so, then try again.
No sound	Volume is in minimum.	Adjust volume to a desired level.
	Wiring is not properly connected.	Check wiring connection.
The operation keys do not work	The built-in microcomputer is not operating properly due to noise.	Press the RESET button. Front panel is not properly fixed into its place
Sound skips.	The installation angle is more than 30 degrees.	Adjust the installation angle to less 30 degrees.
	The disc is extremely dirt or defective disc.	Clean the compact disc. Then try to play a new one.
The radio does not work. The radio station automatic selection does not work.	The antenna cable is not connected.	Insert the antenna cable firmly.
	The signals are too weak.	Select a station manually.
ERROR 1	Mechanism Error	Press the reset button if the error code does not disappear, consult your nearest service dealer.
ERROR 2	Servo Error	Press the reset button if the error code does not disappear, consult your nearest service dealer.